

- Load-holding without leakage
- Low pressure drop
- Pilot seal
- Fits the same cavity as the Q3 overcentre valve

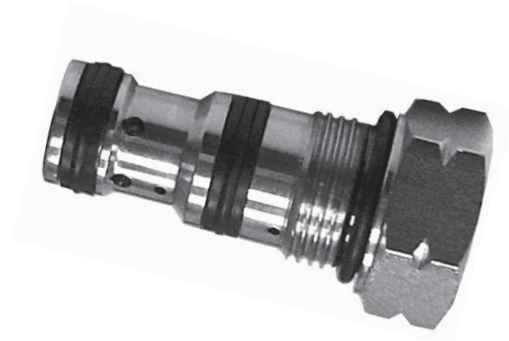
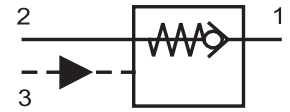

Functional Description

The one-way control valves make the flow possible in one direction with a low pressure drop and prevent from the flow in opposite direction.

The pressure in channel (1) causes a lifting of the valve ball from the seat against the spring. In this way it is released the flow from (1) into (2). The flow in the direction from (2) to (1) is not possible because the spring action and pressure in channel (2) result in pressure exerted to the valve ball in the seat.

The control pressure in channel (3) acts to the control gate valve pressing the valve ball in the appropriate valve seat. In this way the flow is shut off closely in both the directions.

Control pressure for shutting off the valve = $\frac{\text{Pressure of channel (1)}}{2}$

At computing the control pressure it is necessary to take into consideration that the pressure in channel (2) increases the necessary control pressure by the same value multiplied by an efficient differential area having a value of 1-1/2 at a ratio of control areas of 2:1.

As for basic surface treatment the external part of the valve are zinc coated.

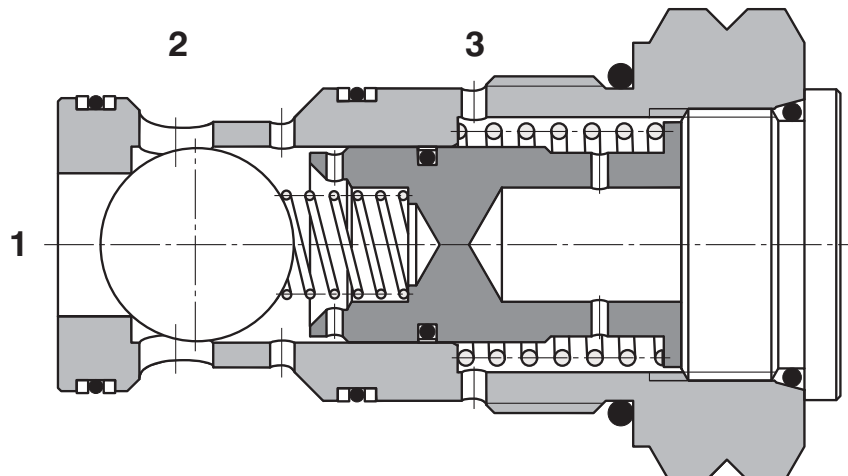

Ordering Code

SC5H-R3/I

Pilot Operated Check Valve
Pilot to close

no designation

Seals
NBR

Pilot ratio
Standard 2:1 **2**

Technical Data

Cavity		M20 x 1.5
Maximum flow	L/min	30
Max. pressure	bar	350
Pilot ratio		2:1
Pressure drops	bar	see $\Delta p - Q$ characteristics
Hydraulic fluid		Hydraulic oil (HM, HV) according to DIN 51524
Fluid temperature range	°C	-20 ... +90
Viscosity	mm ² /s	20 ... 400
Maximum degree of fluid contamination		According to ISO 4406, Class 21/18/15
Weight	kg	0.08
Maximum valve tightening torque in valve body or in control block	Nm	45 ⁺²
Mounting position		Unrestricted

Δp -Q Characteristics

Measured at $v = 40 \text{ mm}^2/\text{s}$

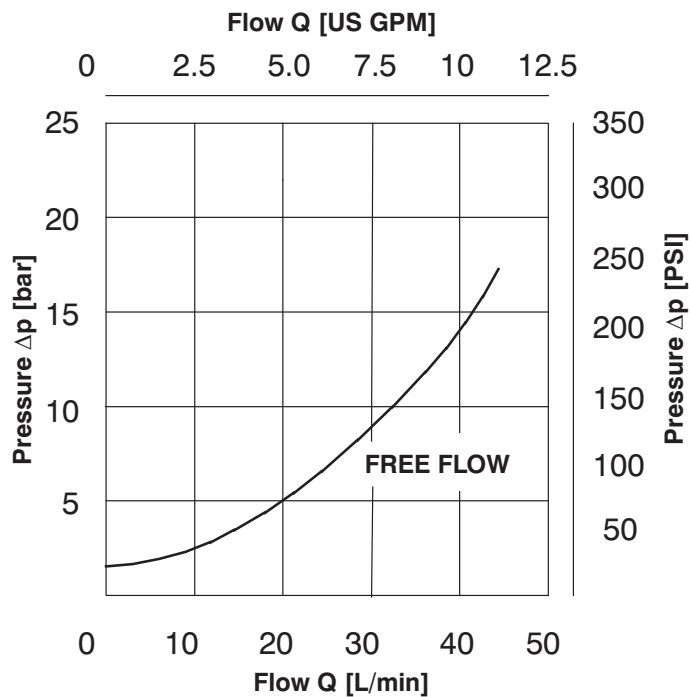

Valve Bodies

Measurements in millimeters

ISO A

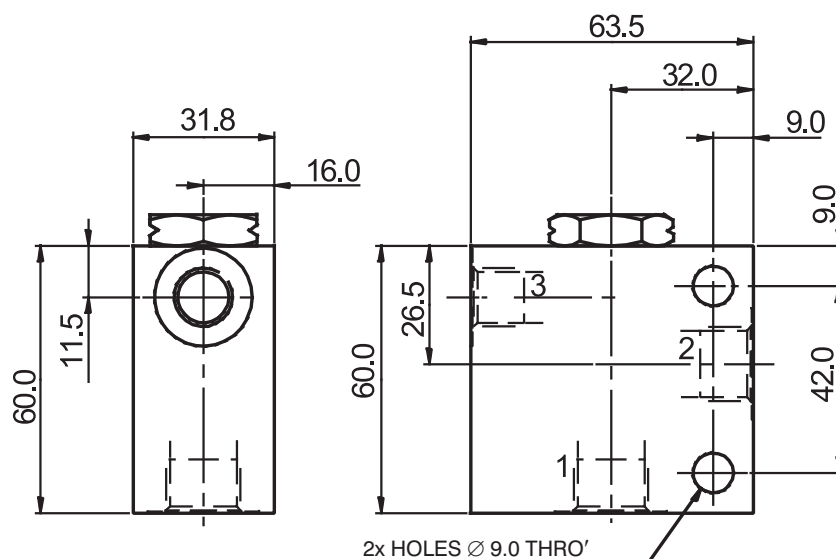
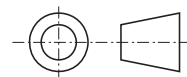

Body without valve			
Material	Ports	Port size	Type code
Aluminium	1, 2	G3/8	SB-R3-0105AL
	3	G1/4	
	1, 2	SAE 8, 3/4-16	SB-R3-0106AL
	3	SAE 6, 9/16-18	
Steel	1, 2	G3/8	SB-R3-0105ST
	3	G1/4	
	1, 2	SAE 8, 3/4-16	SB-R3-0106ST
	3	SAE 6, 9/16-18	

The use of aluminium bodies is limited to a maximum operating pressure of 210 bar.

Spare Parts

Seal kits on request.

Caution!

- The packing foil is recyclable.
- The technical information regarding the product presented in this catalogue is for descriptive purposes only. It should not be construed in any case as a guaranteed representation of the product properties in the sense of the law.

ARGO-HYTOS s.r.o. CZ - 543 15 Vrchlabí
 Tel.: +420-499-403111, Fax: +420-499-403421
 E-mail: sales.cz@argo-hytos.com
 www.argo-hytos.com