

- 4/3, 4/2 way directional control valves
- Cylindrical DC solenoids with removable coils. Electrical connectors can be rotated in three positions 90° apart
- Spool-position sensor optional
- 4 chamber spool - reducing
- Push button manual override
- Installation dimensions to DIN 24 340 / ISO 4401 / CETOP RP121-H
- Subplates see data sheet HA 0002
- CSA Upon request

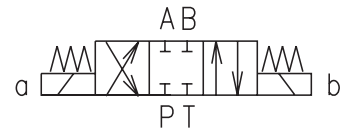

Functional Description

The RPE4-10 directional control valves consist of housing (1), control spool (5), centering springs (4) and operating solenoids (2, 3).

The three-position directional control valves are fitted with two solenoids and two springs. The two position directional control valves have one solenoid and one return spring.

The operating solenoids are DC solenoids and are supplied through connectors (6, 7) without rectifiers. For AC supply the solenoids are provided with rectifiers,

which are integrated directly into the connectors (6, 7) or inside the coil.

By loosening the retaining nut (8), the solenoid can be turned on its axis and locked in three positions 90° apart. Provided that the pressure in T-port does not exceed (25 bar), the spool of the valve can be shifted by manual override (9).

The basic surface treatment of the valve housing (1) is phosphate coated, the operating solenoids (2, 3) are zinc coated.

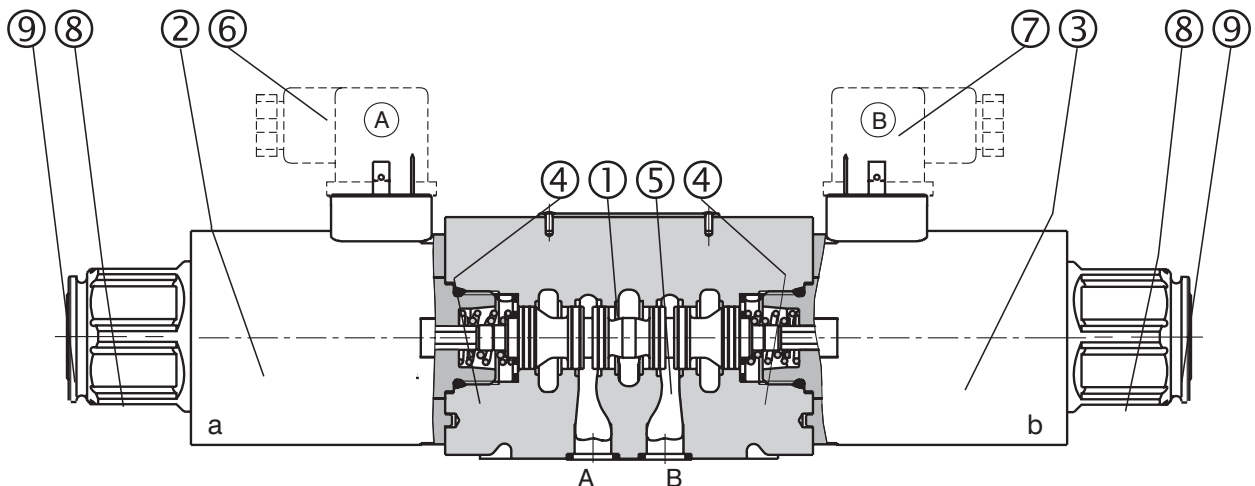

Ordering Code

RPE4-10 /

**Directional Control Valve
Solenoid Operated**

Nominal size

Number of operating positions

two positions
three positions

2
3

Functional symbols

see the table functional symbols

Rated supply voltage of solenoids

(at the coil terminals)

12 V DC / 3.17 A
24 V DC / 1.73 A
205 V DC / 0.20 A
230 V AC / 0.20 A / 50 (60) Hz
120V AC / 60Hz*

01200
02400
20500
23050
 **12060**

The AC coils correspond with E5 type.

CSA Upon request 

Type of the solenoid coil

for the electrical connector, EN 175301-803
with integrated rectifier and for the electrical connector
EN 175301-803

E1
E5

Sensing of the end position

no designation without sensor
S1 normally-open sensor to 50bar
S2 normally-open sensor to 210bar
S4 normally-closed sensor to 50bar

no designation
V

Seals
standard (NBR)
Viton (FPM)

no designation
T2
T3

Damping
without damping
with orifice
with throttle screw

no designation
N2

Manual override
standard
covered with rubber boot

Note: Connector of the position sensor is not supplied
(see ordering number on page 9)

**FOR PREFERRED TYPES SEE BOLD TYPING IN ORDERING CODE, FUNCTIONAL SYMBOLS
AND TABLE OF PREFERRED TYPES ON PAGE 10**

Technical Data

Nominal size	mm	10	
Maximum flow	L/min	see p-Q characteristics	
Maximum operating pressure at ports P, A, B	bar	350	
Maximum operating pressure at port T	bar	50 for version S1, S4 and 210 for version S2	
Pressure drop	bar	see Δp-Q characteristics	
Hydraulic fluid		Hydraulic oils of power classes (HL, HLP) to DIN 51524	
Fluid temperature range (NBR / Viton)	°C	-30 ... +80 / -20 ... +80	
Ambient temperature max.	°C	+50	
Viscosity range	mm ² /s	20 ... 400	
Maximum degree of fluid contamination		Class 21/18/15 to ISO 4406	
Maximum allowable voltage variation	%	AC: ±10	DC: ±10
Maximum switching frequency	1/h	15 000	
Switching time, ON; at v = 32 mm ² /s	ms	AC: 50 ... 330	DC: 50 ... 120
Switching time, OFF; at v = 32 mm ² /s	ms	AC: 100 ... 300	DC: 30 ... 90
Duty cycle	%	100	
Service life	cycles	10 ⁷	
Enclosure type to EN 60529		IP 65	
Weight - valve with 1 solenoid - valve with 2 solenoids	kg	3.9 5.4	
Mounting position		unrestricted	

Functional Symbols

Designation	Symbol	Interposition	Designation	Symbol	Interposition
Z11			P51		
C11			Y51		
H11			C51		
P11			B51		
Y11			Z51		
L21			H51		
B11			X11		
C21			C11		
R11			H11		
R21			J15		
A51			J75		

p-Q Characteristics

Measured at $v = 32 \text{ mm}^2/\text{s}$

Operating limits for maximum hydraulic power transferred by the directional valve. For respective spool type - see functional symbols. The power curves hold true for symmetrical valve flows (e.g. flows in directions P-A and B-T are identical). In case of an asymmetric flow, the power curves can lie substantially lower. In such cases we highly recommend to consult the respective power curve with the valve manufacture.

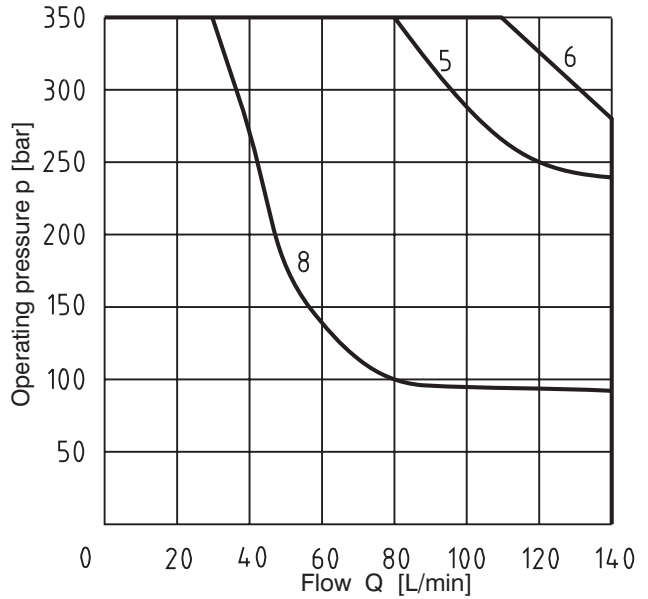
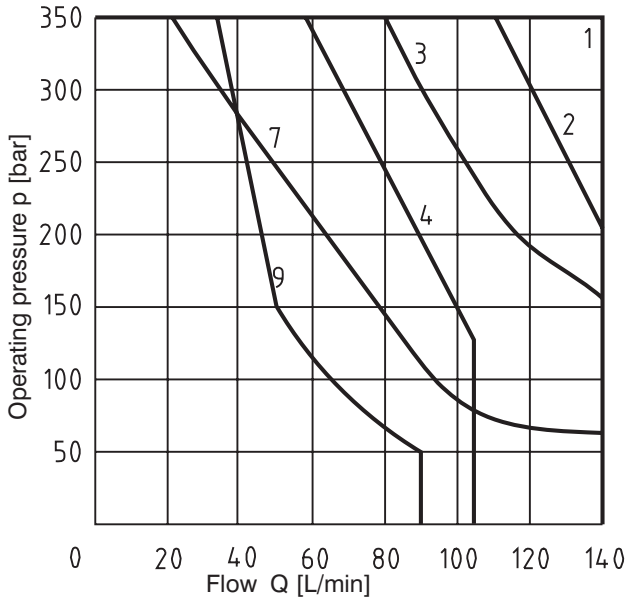

Z11	Z51	H11	H51	P11	P51	Y11	Y51	C11	C51	R11	X11	B11	B51	L21	R21	J15	J75	A51	C21
1	1	1	1	1	1	5	5	3	3	2	2	4	4	7	2	6	6	8	9

Δp -Q Characteristics

Measured at $v = 32 \text{ mm}^2/\text{s}$

Pressure drop Δp related to flow rate.

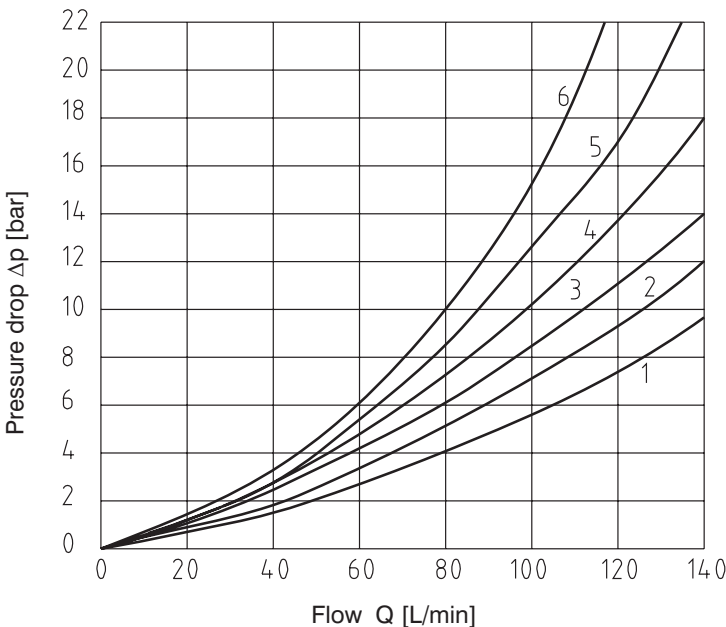

	P-A	P-B	A-T	B-T	P-T
Z11	1	1	2	2	
Z51		1	2		
H11	1	1	2	2	1
H51		1	2		1
P11	1	1	2	2	
P51		1	2		
Y11	1	1	2	2	
Y51		1	2		
C11	4	3	4	5	1
C51	4			5	1
R11	1	1	2	2	
X11	1	1	2	2	
B11	1	1	2	2	
B51		1	2		
L21	1	1	1	2	2
R21	1	1	1	3	
J15	1	1	2	3	
J75	1	1			
A51	1	1			
C21	6	6	6	6	4

Valve Dimensions

Dimensions in millimetres

Valve with two solenoids

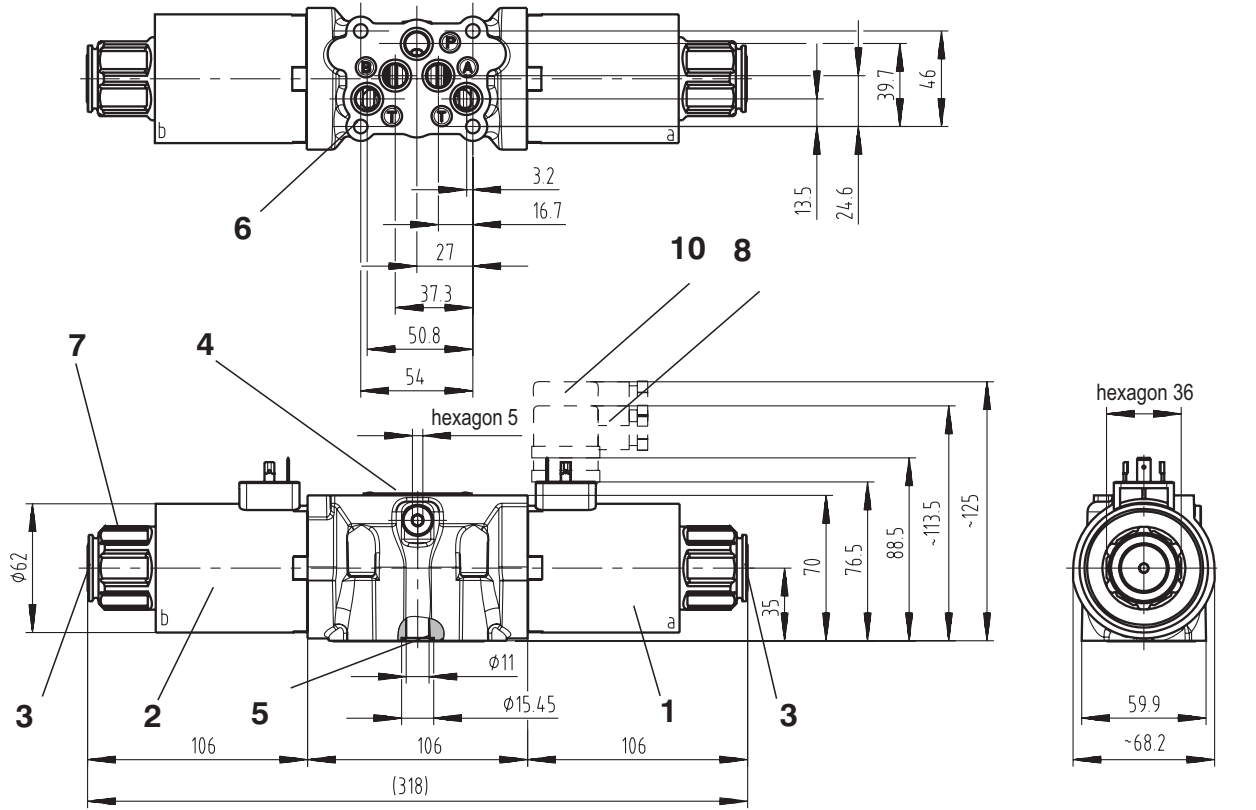

Valve with one solenoid "a"

Functional symbols R11, R21, Y51, C51, Z51, H51,

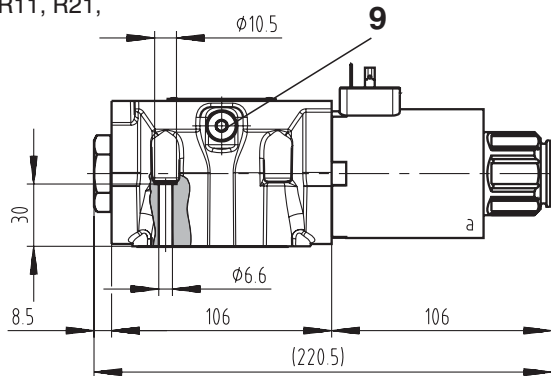

Valve with one solenoid "b"

Functional symbols C11, H11

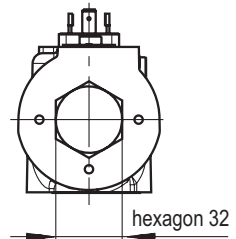
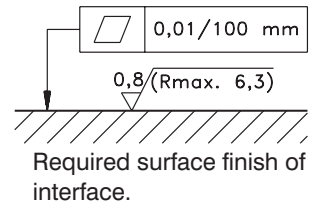
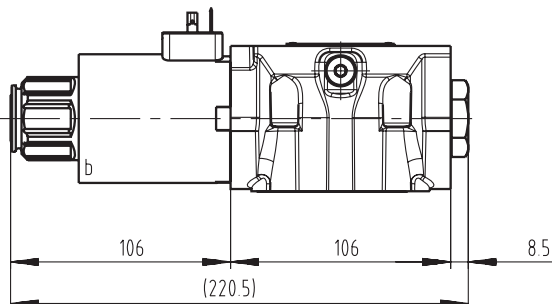

- 1 Solenoid a
- 2 Solenoid b
- 3 Manual override
- 4 Name plate
- 5 Square ring 12,42 x 1,68 (5 pcs.) supplied with valve
- 6 4 mounting holes
- 7 Retaining nut of the solenoid
- 8 Electrical connector, EN 175301-803
- 9 Throttle screw
- 10 Space required to remove connector

Type of the Solenoid Coil

E1

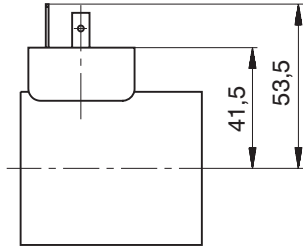

Solenoid coil with terminal for the electrical connector, EN 175301-803

E5

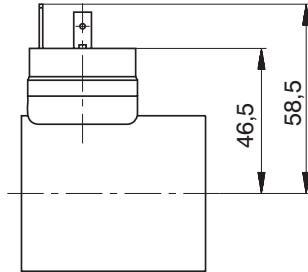

Solenoid coil with integrated rectifier and terminal for electrical connector, EN 175301-803

Manual Override

Standard

Rubber boot

Without designation
Dimensions

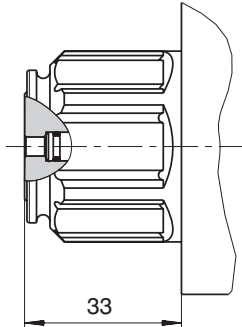
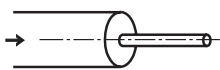

Description:
Standard model of the manual override.
Standard retaining nut of the solenoid.

Designation **N2**
Dimensions

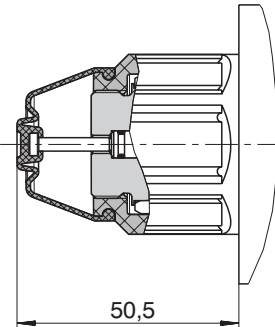
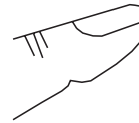

Description:
Manual override protected by rubber boot.

Soft Shifting Spool Options Delay Time

T2 - Nozzle $\varnothing 0,6$

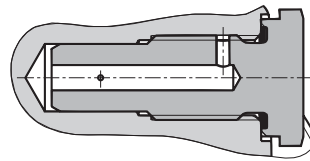
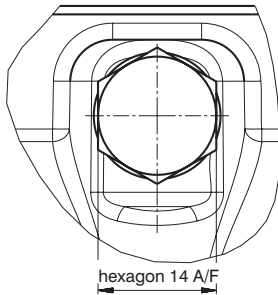

The orifice extends the valve shifting time.

Switching times

Switching time, on and off	ms	120 ... 350
----------------------------	----	-------------

T3 - Throttle Screw

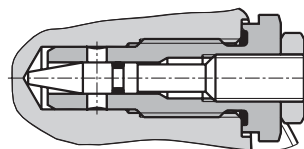
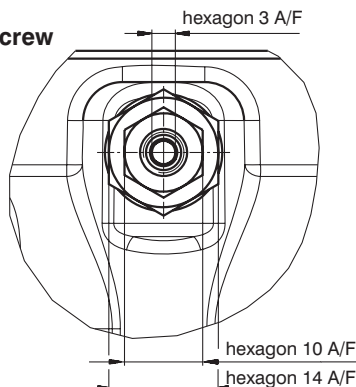

The control orifice allows for stepless adjustment of the valve shifting time.

Switching times

Switching time, on and off	ms	30 ... 2000
----------------------------	----	-------------

Spool Position Sensor

S1, S2 - Circuit diagram of the normally-open sensor

S4 - Circuit diagram of the normally-closed sensor

The proximity sensor transforms the spool position into an electrical step signal. It can be used with directional control valves with one or two solenoids.

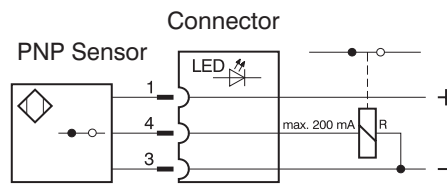
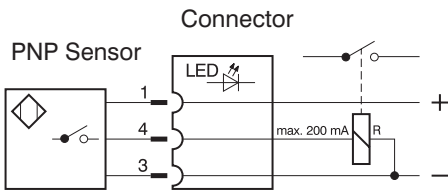

Technical Data of the Sensor

		S1, S4	S2
Rated power supply voltage	V		24 DC
Power supply voltage range	V		10 ... 30 DC
Rated current	mA		200
Enclosure type of sensor to EN 60529			IP 67
Max. operating pressure	bar	50	210
Switching frequency	Hz		1000
Ambient temperature range	°C		-25 ... +80

Technical Data of the Connector

Power supply voltage range	V	10 ... 30 DC
Ambient temperature range	°C	-25 ... +80
Indication		yellow LED

Two-Position Directional Control Valve

Dimensions in millimeters

Signal of solenoid a (b)	Signal of sensor Sa (Sb)		LED	
	S1, S2 - normally-open	S4 - normally-closed	S1, S2	S4
0	1	0	ON	OFF
1	0	1	OFF	ON

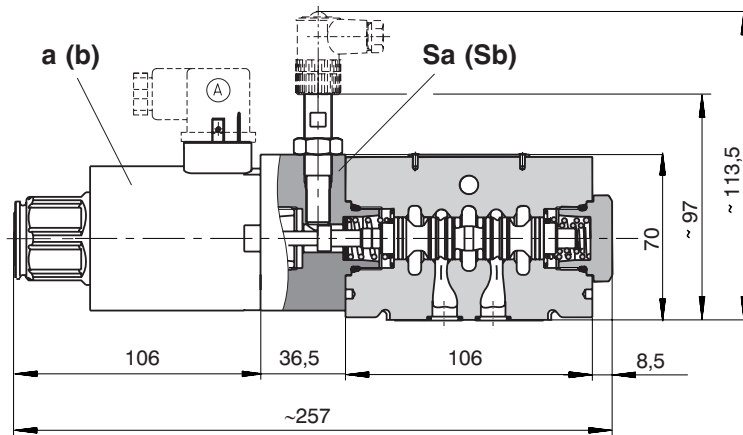

Three-Position Directional Control Valve

Dimensions in millimeters

Signal of solenoid		Signal of sensor Sa (Sb)				LED			
a	b	S1, S2 - normally-open		S4 - normally-closed		S1, S2		S4	
		Sa	Sb	Sa	Sb	Sa - LED	Sb - LED	Sa - LED	Sb - LED
0	0	1	1	0	0	ON	ON	OFF	OFF
1	0	0	1	1	0	OFF	ON	ON	OFF

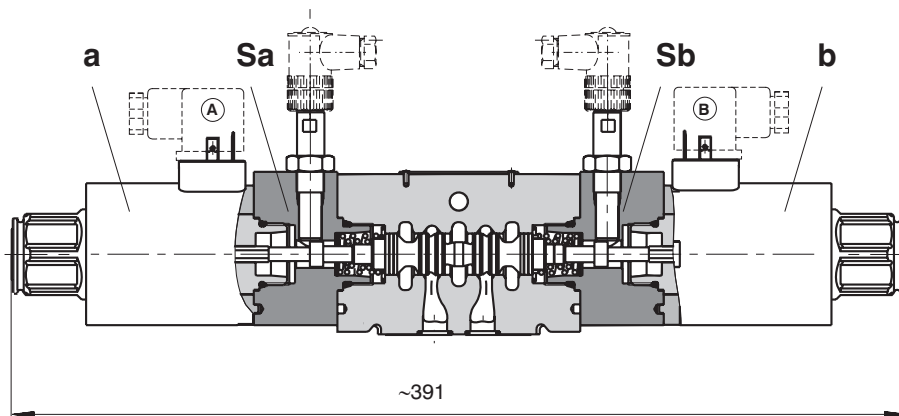

Spare Parts

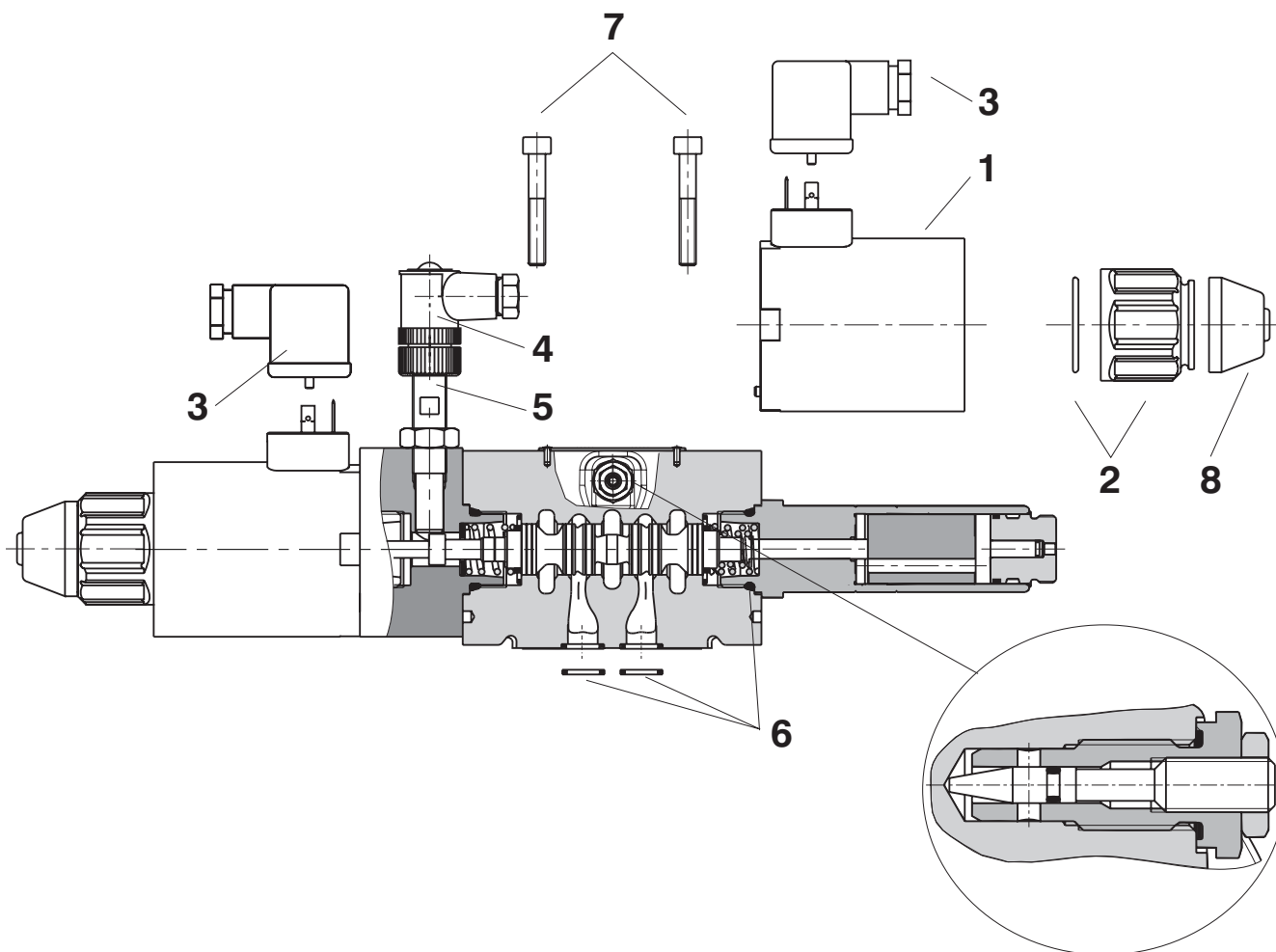

- 1 Solenoid coil
- 2 Nut with seal
- 3 Electrical connector
- 4 Connector of position sensor with LED
- 5 Sensor
- 6 Seal kit
- 7 Mounting bolts
- 8 Rubber cap with manual override

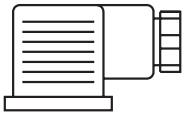
Solenoid coil				
Type designation of the coil voltage	Type of the coil			
	E1	E5		
	Ordering number			
01200	16195700			
02400	16196100			
20500	23898000			
23050		16195100		
12060		16195000		
Solenoid retaining nut with seal				
Type of the nut	Seal ring	Ordering number		
Standard nut	30 x 2	15900800		
Rubber cap with manual override		15900900		
Connector of position sensor				
Type designation	Model	Max. input voltage	Ordering number	
K02	connector of position sensor with LED	10...30 V DC	17364800	
S1	normally-open sensor	10...30 V DC	405111129213	
S2	normally-open sensor	10...30 V DC	18838900	
S4	normally-clsd sensor	10...30 V DC	20725300	
Seal kit				
Type	Dimensions		Ordering number	
	Square ring	O-ring		
Standard NBR70	12,42 x 1,68 (5 pcs.), 11,9 x 8,4 x 1 (1 pc.)	23,81 x 2,62 (2 pcs.), 1,8 x 1 (1 pc.)	15847500	
Viton	12,42 x 1,68 (5 pcs.), 11,9 x 8,4 x 1 (1 pc.)	23,47 x 2,62 (2 pcs.), 1,8 x 1 (1 pc.)	15847800	
Mounting bolts				
Dimensions	Tightening torque	Ordering number		
M6 x 40 DIN 912-10.9 (4 pcs.)	14+2 Nm	15847700		
Soft Shift Conversion Kit				
T2	10 Nm	15901200		
T3	10 Nm	15901300		
Electrical connector, EN 175301-803				
Type designation	Connector A grey	Connector B black		
	Ordering number			
K1	16202200	16202100		
K5	16202600	16202500		
K2	16202800	16202700		
K3	16202400	16202300		
K4	16203000	16202900		
Electrical Connector, EN 175301-803				
K1	Connector B (black)	without rectifier - M16x1.5 (bushing bore \varnothing 6-8 mm)	230 V AC/DC	
	Connector A (grey)			
K5	Connector B (black)	without rectifier - M16x1.5 (bushing bore \varnothing 4-6 mm)	230 V AC/DC	
	Connector A (grey)			
K2	Connector B (black)	without rectifier with LED and quenching diode - M16x1.5 (bushing bore \varnothing 6-8 mm)	12 ... 24 V DC	
	Connector A (grey)			
K3	Connector B (black)	with rectifier - M16x1.5 (bushing bore \varnothing 6-8 mm)	230 V AC	
	Connector A (grey)			
K4	Connector B (black)	with rectifier with LED and quenching diode - M16x1.5 (bushing bore \varnothing 6-8 mm)	230 V AC	
Recommended solenoid coils used with electrical connector with rectifiers - type designation K3, K4				
Rated supply source voltage (permissible rated voltage variation ± 10 %)		Type designation of the solenoid voltage		
230 V AC / 0.17 A / 50 (60) Hz		20500		

Preferred Types

Type	Ordering number	Type	Ordering number
RPE4-103Z11	15888500	RPE4-103Z11/02400E1	15889500
RPE4-102Z51	15892000	RPE4-102Z51/02400E1	15892300
RPE4-103C11	15888700	RPE4-103C11/02400E1	15890000
RPE4-102C51	15892100	RPE4-102C51/02400E1	15892500
RPE4-103H11	15889000	RPE4-103H11/02400E1	15892700
RPE4-103Y11	15888900	RPE4-103Y11/02400E1	15893100
RPE4-102R11	15889100	RPE4-102R11/02400E1	15890700
RPE4-102R21	15889200	RPE4-102R21/02400E1	15893400
RPE4-102Y51	15892200	RPE4-102Y51/02400E1	15893700
RPE4-103Z11/01200E1	15891600	RPE4-103Z11/23050E5	21867800
RPE4-102Z51/01200E1	15891200	RPE4-102Z51/23050E5	21868300
RPE4-103C11/01200E1	15891700	RPE4-103C11/23050E5	21868500
RPE4-102C51/01200E1	15891500	RPE4-102C51/23050E5	21868800
RPE4-103H11/01200E1	15891000	RPE4-103H11/23050E5	21862100
RPE4-103Y11/01200E1	15890400	RPE4-103Y11/23050E5	21868900
RPE4-102R11/01200E1	15891900	RPE4-102R11/23050E5	21869400
RPE4-102R21/01200E1	15891300	RPE4-102R21/23050E5	21869900
RPE4-102Y51/01200E1	15891400	RPE4-102Z51/23050E5	21870100

Caution!

- In the case of directional valves with two solenoids, any of the solenoids may be energized, but only after switching off the other.
- Directional valves with other functional symbols as those shown in the table, please consult with the manufacturer.
- The packing foil is recyclable.
- The protective plate can be returned to manufacturer.
- Mounting bolts M6 x 40 DIN 912-10.9 or studs must be ordered separately.
- The technical information regarding the product presented in this catalogue is for descriptive purposes only. It should not be construed in any case as a guaranteed representation of the product properties in the sense of the law.
- For RPEW4-10 with CSA only: Use supply wires suitable for at least 75°C.

ARGO-HYTOS s.r.o. CZ - 543 15 Vrchlaví
 Tel.: +420-499-403111, Fax: +420-499-403421
 E-mail: sales.cz@argo-hytos.com
 www.argo-hytos.com