

## PORTABLE PULLER

MAX. CAPACITY: 100 TONS

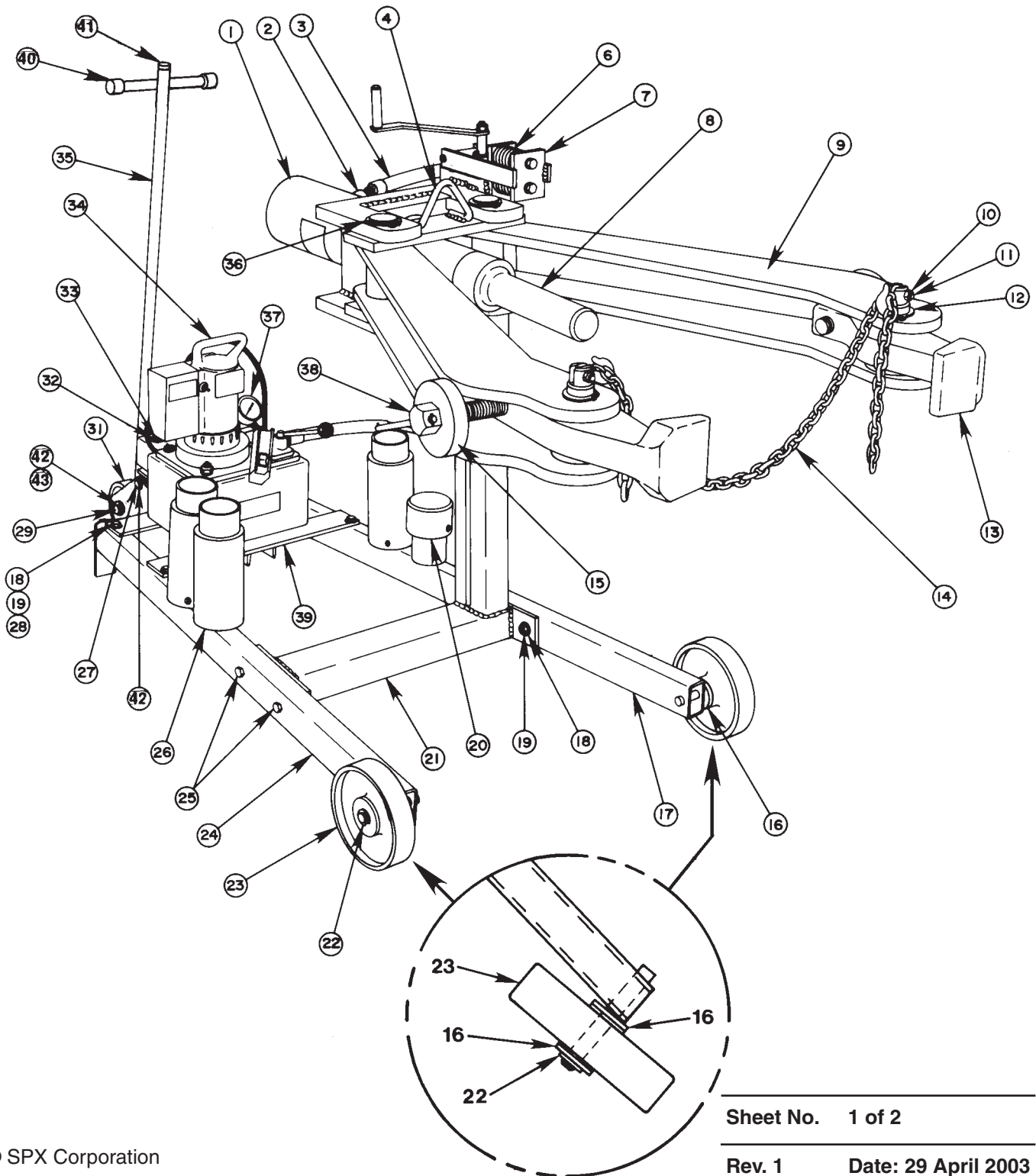

# Parts List, Form No. 100494, Back sheet 1 of 2

Item No.	Part No.	No. Req'd	Description
1	C10010C	1	Cylinder Ass'y (see Form #100385; for PH1002 & PH1002J)
2	303839	1	Hose Half Coupler (for PH1002 & PH1002J)
3	37283	1	Hydraulic Hose (for PH1002 & PH1002J)
4	44762	1	Lifting Plate (with lifting eye)
6	207522	2	Compression Spring
7	44751	1	Bracket
8	44745	1	Pushing Adapter
9	51857	4	Puller Arm
10	10201	2	Hex Nut (5/16-18)
11	10036	2	Hex Hd. Cap Screw (5/16-18 x 2" Lg.)
12	207472	4	Retaining Ring (for 1-11/16 Dia.)
13	51859	2	Jaw
14	207516	1	Chain
15	303053	2	Jaw Adjusting Block
16	10236	4	Washer (for 3/4 Dia.)
17	60925	1	Left Leg
18	10231	12	Washer (for 3/8 Dia.)
19	10204	8	Hex Nut (3/8-16)
20	303045	1	End Adapter
21	60924	1	Upright
22	11902	2	Retaining Ring (for 3/4 Dia.)
23	17786	2	Wheel (8" Dia.)
24	60926	1	Right Leg
25	13201	4	Hex Hd. Cap Screw (3/8-16 x 2-3/4 Lg.)
26	44766	4	Adapter
27	309260	1	Pin

Item No.	Part No.	No. Req'd	Description
28	10062	4	Hex Hd. Cap Screw (3/8-16 x 4" Lg.)
29	309262	1	Pin
31	12078-1	1	Wheel (5" Dia.)
32	11998	1	Retaining Ring (for 3/4 Dia.)
33	47762	1	Pivot Block
34	PE552	1	Electric Hyd. Pump (see Form #16512; for PH1002 only)
35	53422	1	Dolly Assembly
36	207471	4	Retaining Ring (for 3/4 Dia.)
37	16457	1	Gauge (for PH1002 & PH1002J)
38	44746	2	Hand Screw
39	60937	1	Pump Mounting Plate
40	209550	2	End Cap
41	207655	1	Tube Cap
42	14855	4	Retaining Ring (for 3/4 Dia.)
43	12330	2	Washer

### PARTS INCLUDED BUT NOT SHOWN

303132	1	Trade Name Decal
303130	2	Warning Decal
10435	2	Soc. Hd. Cap Screw (3/8-16 x 2-1/2 Lg.)
303040	1	Ram Adapter
17395	1	Cotterless Hitch Pin
10622	1	Street Elbow (for attaching hose to valve on PH1002 & PH1002J)
10077	4	Hex Hd. Cap Screw (for mtg. pump on PH1002 & PH1002J)
12004	4	Washer (for mtg. pump on PH1002 & PH1002J)

## PIVOT DOLLY ASSEMBLY

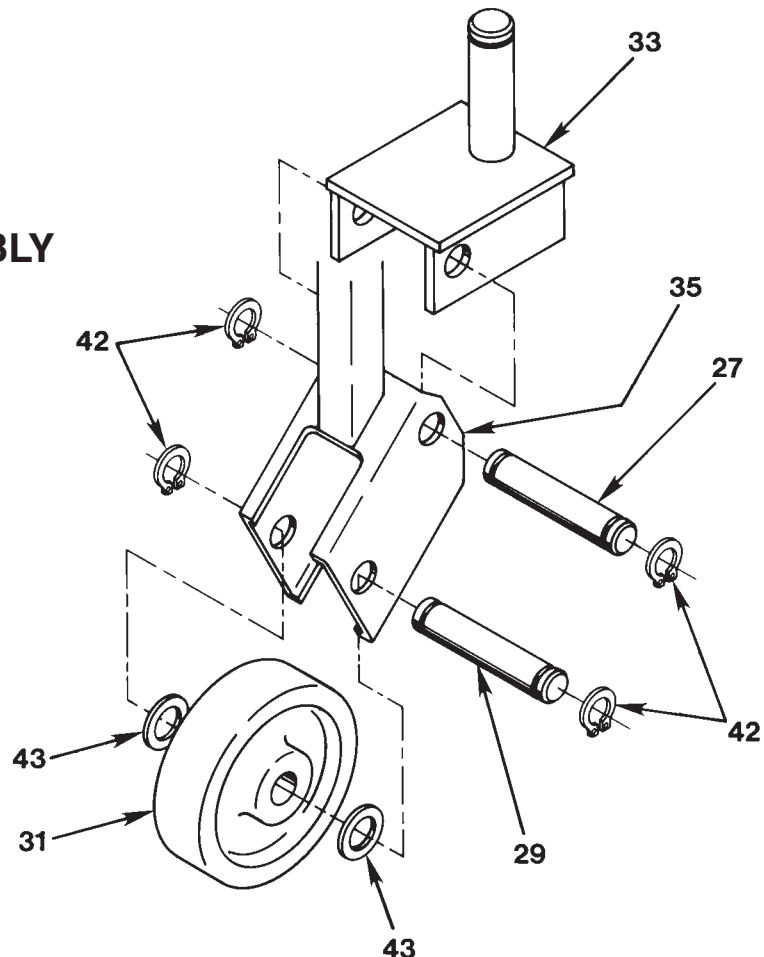

# LIFT ASSEMBLY

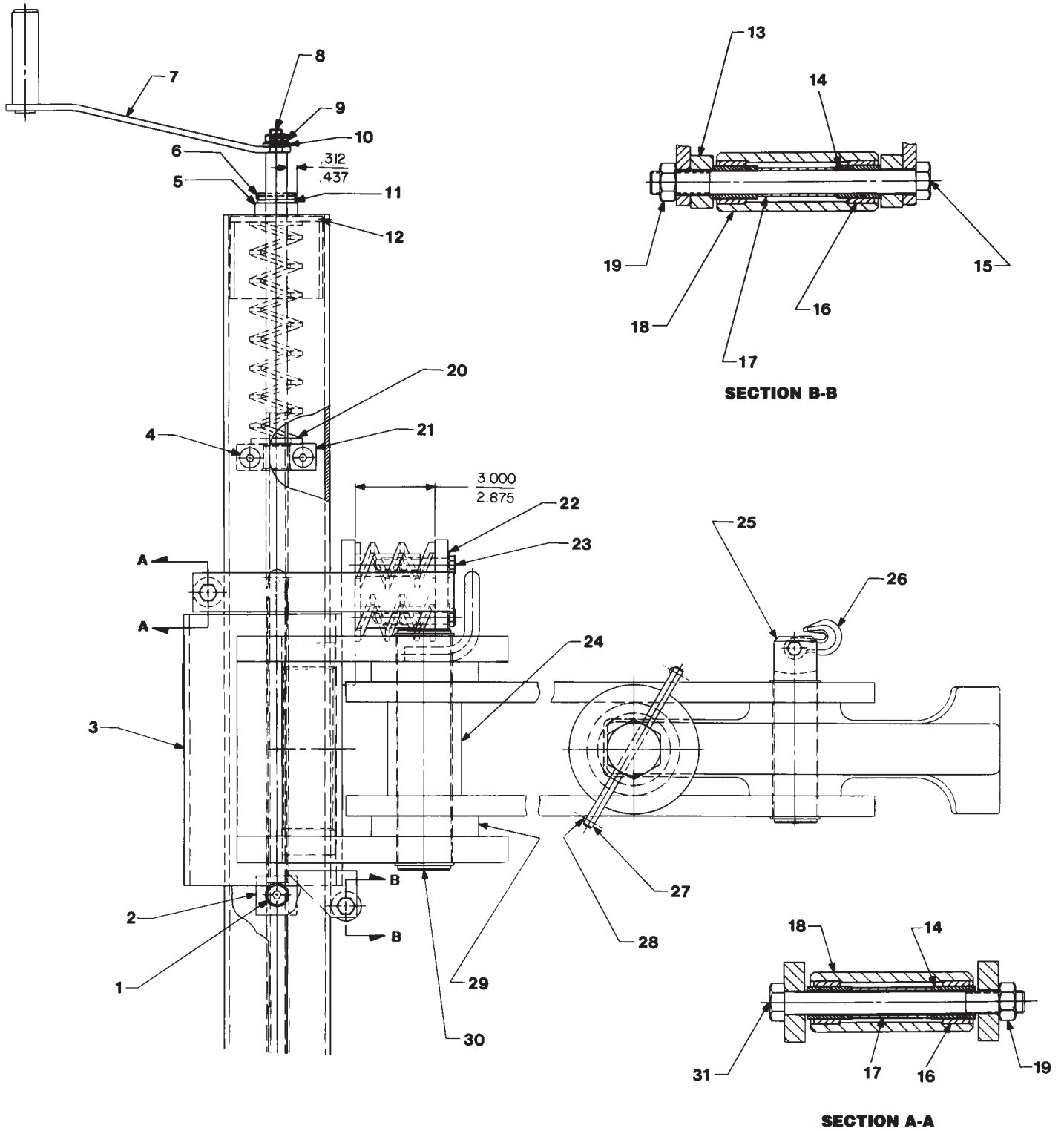

## Parts List, Form No. 100494, Back sheet 2 of 2

Item No.	Part No.	No. Req'd	Description
1	207459	2	Hex Soc. Hd. Shoulder Screw
2	303030	1	Block
3	60923	1	Puller Head
4	10518	4	Flat Soc. Hd. Cap Screw
5	12702	1	Thrust Bearing
6	10982	1	Roll Pin (1/4 Dia.)
7	25852	1	Handle
8	303108	1	Threaded Rod
9	15013	1	Hex Locknut (1/2-13)
10	12004	1	Washer
11	12330	1	Washer
12	303033	1	Spring Cap
13	207458	2	Spacer
14	207517	4	Inner Race
15	15518	1	Hex Hd. Cap Screw (7/16-14 x 5" Lg.)
16	12192	4	Needle Roller Bearing
17	207513	2	Spacer
18	207464	2	Roller
19	10206	2	Hex Nut (7/16-14)
20	207521	1	Compression Spring
21	303032	1	Block
22	201608	2	Washer
23	12896	2	Hex Hd. Cap Screw (1/2-13 x 2-1/4 Lg.)
24	207457	2	Tube
25	44770	2	Pin
26	16360	2	Grab Eye Hook
27	201266	2	Turning Bar
28	12090	4	Drive Screw
29	44750-GY8	1	Spacer Plate
30	303041	2	Pin (2-1/16 Dia.)
31	207514	1	Hex Hd. Cap Screw (7/16-14 x 4-1/2 Lg.)

Refer to any operating instructions included with this product for detailed information about operation, testing, disassembly, reassembly and preventive maintenance.

Items found in this parts list have been carefully tested and selected. **Therefore: Use only genuine replacement parts!**

Additional questions can be directed to our Technical Services Department.